

IT-SH302-WL

With 60 high power LEDs for a total power consumption of 74W, beam angle 15° to 180°, beam distance 220m to 35m, the IT-SH302-WL is a White Light Illuminator with a high service of life.

- Luminous flux 6600lm-7200lm.
- Color temperature 3000-3500K/6500-7000K.
- 50,000 hours lifetime LEDs.
- Extended working temperature range -40 to 50°C.
- 1-5 years warranty.



Product Family

The IT-SH302-WL is part of the high-power Industrial & Military White Light Illuminators series that is the top quality LED light source solution for night-time illumination, providing high-power light for CCTV and IP cameras to enhance night-time visual performance with colorful images.

Professional Design

- Two stages of constant current circuit avoid LEDs away from instantly impulse impact when started.
- A wide edge of silica gel waterproof circle and water stop line ensure excellent waterproof performance.
- Twice direct cooling heat sink processing enable to increase the cooling coefficient and prolong the service life of the product.
- Patent design hexagonal spherical light sensor more accurately responses ambient brightness and improves accuracy of automatic light control.
- Flexible angle adjustable bracket can extend the illuminance range widely.
- Robust cooling fin design permits the white light illuminator to operate at -40°C to 50°C.

Qualified Materials

- Super power dot-matrix white light LED with strong light effect, long service life and low light decline.
- High efficient twice optical lens processing achieves 90% of the luminous efficiency.
- The housing adopts high thermal conductivity aluminum to enhance heat dispersion property.
- Stainless steel bracket and screw ensure low maintenance.

Wide Range of Applications

Recommended for security at ports, railway systems, border, prisons, traffic LRP/ANPR, ITS, as well as large public places lighting.

Basic Functions

- *To improve performance of the weak light camera, thereby enhancing the picture effects at night.*
- *Conventional night monitoring.*
- *The function of video analysis at night.*
- *Reduce signal noise and other image distortion.*
- *Reduce the network bandwidth requirements.*
- *Energy saving by power factor correction.*
- *Reduce the equipment cost.*
- *Lower cost of installing and wiring.*
- *Provide colorful picture for camera.*

Technical Specifications

LED type: 60 pieces dot-matrix white light LEDs

Color temperature: 3000-3500K/6500-7000K

Luminous flux: 6600lm-7200lm

Voltage: AC85-265V/DC12V/AC24V

Power consumption: 74W

Day & Night switch: Auto (build in photocell)

Cable: 1.3m waterproof cable

Mounting: Wall mounting "U" bracket

Temperature: -40°C to 50°C

Grade of protection: IP66

Color: Black

Housing: Aluminum

Panel: High light transmittance toughened glass

Net weight: 7.8 kg

Gross weight: 8.5 kg

Dimensions: 414*273.5*146mm

Packing dimensions: 520*400*220mm

Models for Selection

Model	Beam angle	Viewing distance
IT-SH302-WL-15-W	15° - 30°	220m - 150m
IT-SH302-WL-30-W	30° - 60°	160m - 120m
IT-SH302-WL-45-W	45° - 90°	120m - 80m
IT-SH302-WL-60-W	60° - 110°	100m - 75m
IT-SH302-WL-75-W	75° - 130°	80m - 65m
IT-SH302-WL-90-W	90° - 140°	65m - 50m
IT-SH302-WL-120-W	120° - 180°	50m - 35m

*Viewing distance is tested by Sony 1/3 CCD Camera.

To achieve the distance needed, please pay attention to your camera specifications and lens before purchase. It is normal phenomenon that distance may vary due to different cameras and lens.

Mechanical Drawings

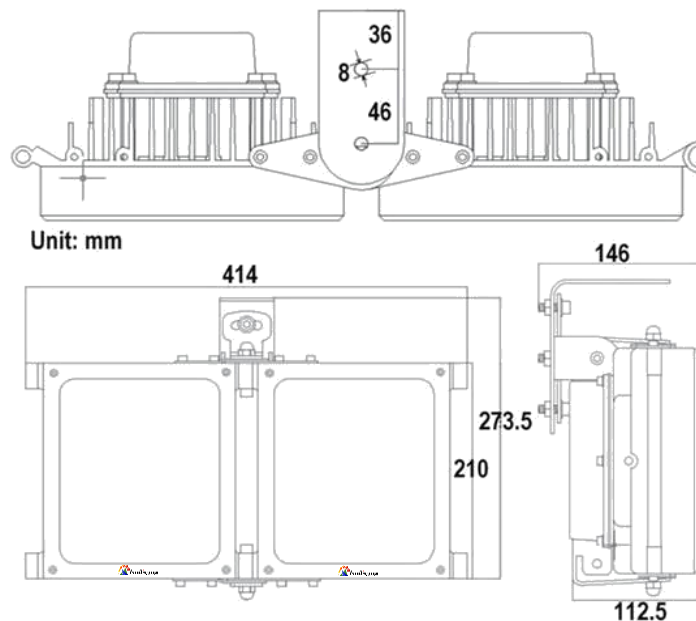

Viewing Picture at Night

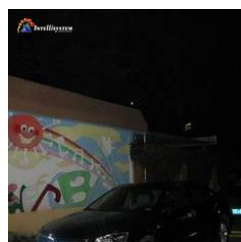

With white light

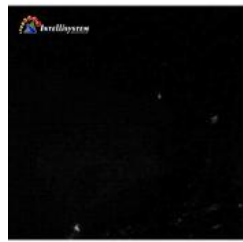

Without white light



All products, product specifications and data are subject to change without notice.